

| Colour Code | |
|-------------|-----------|
| B | Black |
| U | Blue |
| N | Brown |
| G | Green |
| K | Pink |
| P | Purple |
| R | Red |
| W | White |
| Y | Yellow |
| L | Light |
| S | Slategrey |

Note 1
 Canadian Models Have Headlamp Warning Unit In Place Of Ignition Warning Light Unit
Connections
 HL (U)
 WL (WN)
 AL (GY)
 TL (NG)
 R&W Wires Not Used On Canadian Models

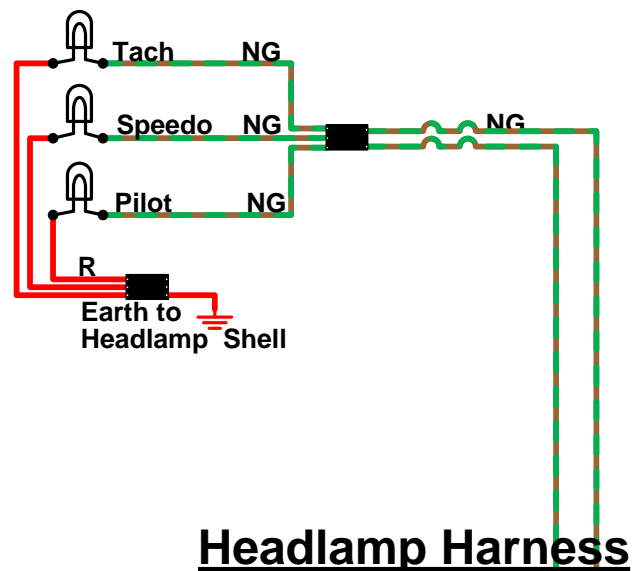

Main Harness

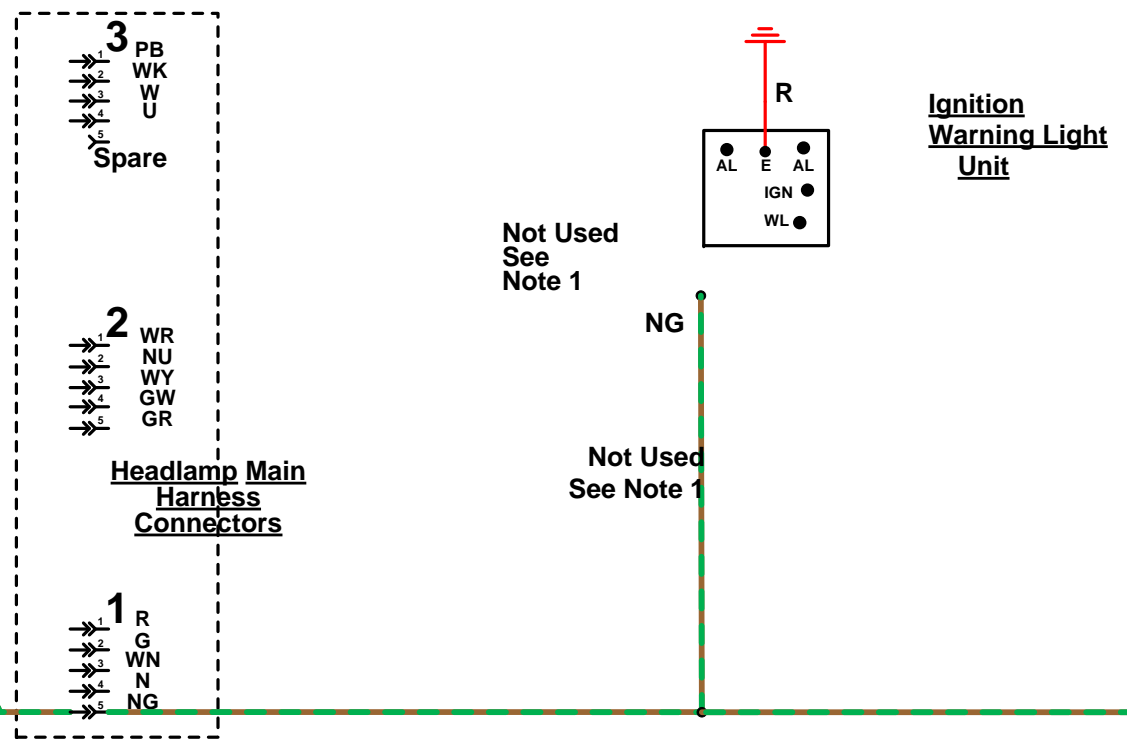

T1 – T3 Park Lights
The T3 contact provides power to the Pilot light, Tack, Speedometer, and Tail light.

